

Refrigeration Equipment 1-Door Full Height Reach In Back Room Freezer 31" Long

ITEM # _____

MODEL # _____

NAME # _____

SIS # _____

AIA # _____



738279 (KCHRI25R1DFE)

1-Door Full Height Reach In
Back Room Freezer 31" Long

Short Form Specification

Item No. _____

1 full door freezer with door in 430 stainless steel, exterior back and bottom panels in galvanized steel, exterior side and top panels in pre-painted steel; interior back, side, top and bottom panels in white High Impact Polystyrene. Control with cabinet temperature display. Self-closing and on-site reversible door feature with lock and key.

Cabinet capable of accepting a full-size sheet pan (18X26).

R290 gas in the refrigeration circuit.

ETL Safety and Sanitation certifications.

3/5 Years warranty.

Main Features

- External temperature display.
- Removable gasket for easy cleaning operations.
- Fin & Tube Condenser improves performance in high temperature environments.
- Automatic Defrost Cooling System provides worry-free performance.
- Electronic Temperature Control, quick and simple to set, with control display for easy monitoring.
- Heavy duty Vinyl coated steel shelves.
- Cabinet completely insulated with high density polyurethane for low environmental impact.
- Back bottom mounted cooling unit guarantee an easy access and cleaning.
- Adjustable shelves for flexible storage
- Cabinet capable of accepting a full-size sheet pan (18X26)
- Heavy duty vinyl coated steel floor protector shelves

Construction

- Painted gray steel exterior, for durable and sleek finish
- White polystyrene interior, for high impact resistance
- Stainless steel door(s) for long lasting performance
- Lockable door.
- Self-closing door with 90-degree stay-open feature.
- Heavy duty casters.
- Pre-wired heavy duty power cord.
- Heavy duty door hinges.
- Magnetic gasket removable without tools for easy cleaning.
- Door reversible on site

Sustainability

- CFC and HCFC free, highly ecological refrigerant type: R290 (ecological gas in foam: cyclopentane). Hydrocarbon refrigerant gas R290 for the lowest environmental impact (GWP=3), to reduce green house and ozone depletion effects.
- Hydrocarbon refrigerant gas R290 for the lowest environmental impact (GWP=3) - CFC and HCFC free.
- High efficiency components to minimize the energy consumption still guaranteeing the highest performances.
- 60 mm insulation for energy saving.

Optional Accessories

- Shelf clips (4-pack) PNC 880611
- Shelf for 25 Cu. Ft. Reach-In PNC 880678

APPROVAL: _____

Front

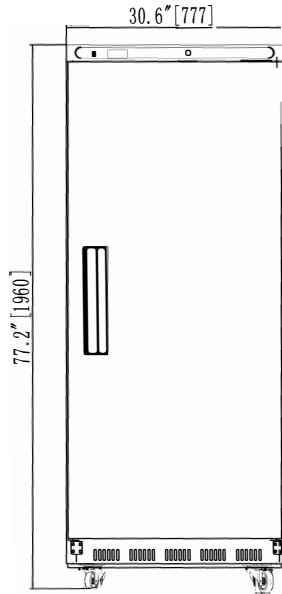

Side

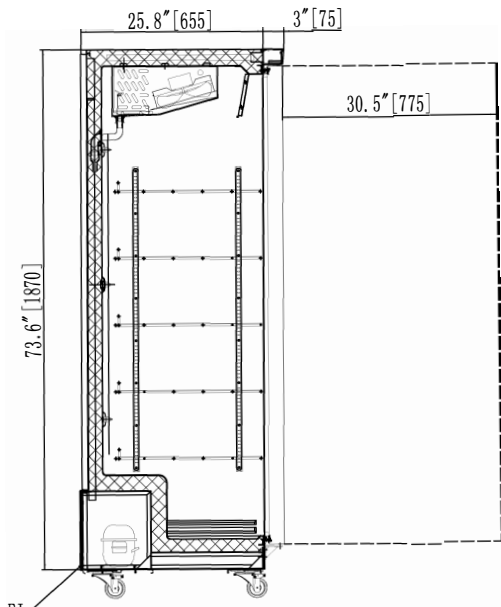

EI = Electrical connection

Top

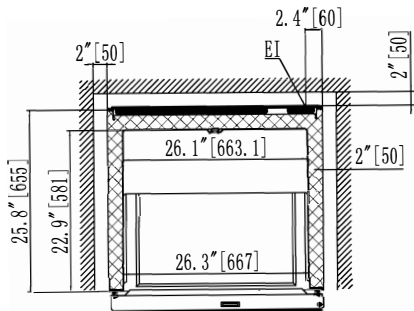

Electric

Supply voltage:	115 V/1 ph/60 Hz
Electrical power, max:	0.41 kW
Plug type:	USA NEMA 5-15P

Capacity:

Gross capacity:	22.7 cu.feet
-----------------	--------------

Key Information:

Number and type of grids (included):	3+1 - Vinyl-Coated steel
Warranty:	3 / 5 years
Door hinges:	Right Side
External dimensions, Width:	30 9/16" (777 mm)
External dimensions, Depth:	28 3/4" (730 mm)
External dimensions, Height:	77 3/16" (1960 mm)
Number and type of doors:	1 Full
Internal Dimensions (depth):	22 3/4" / (578 mm)
Internal Dimensions (height):	65 3/8" / (1660 mm)
Internal Dimensions (width):	26 3/8" / (670 mm)
Shipping height:	82 11/16" (2100 mm)
Shipping weight:	284 lbs (129 kg)
Shipping volume:	47.34 ft ³ (1.34 m ³)
Type of external material:	Prepainted Steel
Type of internal material:	High Impact White Polystyrene
Approvals	ETL C&US;ETL SANITATION

Refrigeration Data

Condenser type:	Fin & tube
Operating temperature min.:	-10.01 °F
Compressor power:	3/4 hp
Operating temperature max.:	0 °F
Defrost type:	auto defrost

Sustainability

Current consumption:	8 Amps
Refrigerant type:	R290
GWP Index:	3
Refrigerant weight:	119 g

Refrigeration Equipment 1-Door Full Height Reach In Back Room Freezer 31" Long

The company reserves the right to make modifications to the products without prior notice. All information correct at time of printing.

